

Framech Industries

Delivers Precision Engineering

We offer a range of products to help clients grow their business.





ABOUT US

At Framech Industries, we design and produce precision-engineered components and fittings made from stainless steel, mild steel, and aluminum alloys. These components and fittings find broad usage across various industries.

Our manufacturing facilities, equipped with modern technology, are located in Ahmedabad. This city is part of the booming industrial cluster in India, which enables us to manufacture cost-effective products that fulfill the increasing needs of our customers. As a result, we have emerged as one of the leading manufacturers in India and are competing in the international market.

DELIVERING VALUES

MANUFACTURING AND SUPPLYING

Making Precision Engineered Parts and Components from CNC turning, CNC Milling, casting, and stamping from stainless steel, aluminum alloy, and many ferrous and non-ferrous metals.

ON TIME DELIVERY OF PARTS

we have implemented the visual system to measure workflow process in our manufacturing facilities for raw components, sub-assembly and finished parts and components. This is not only in our systems moreover it is one of our company's main goals.

QUALITY ASSURANCE

Adopted Various quality systems and certifications for producing world class quality components

BUILD TO ORDER

We have expertise in customized manufacturing and subcontracting for domestic and overseas clients. In fact, customized manufacturing is more than 85% turnover of our company.

EXPORTING GLOBALLY

We have a dedicated team enthusiastically working on export orders for all operations right from communications with customers, production, export-worthy packing, export documentation and logistics. We make sure, Parts and Components reaches to the customer anywhere located in the globe.

VISION

Unlocking our company's potential to compete at a global level.

MISSION

Providing quality to the customers around the world and delivering exceptional value to their business.

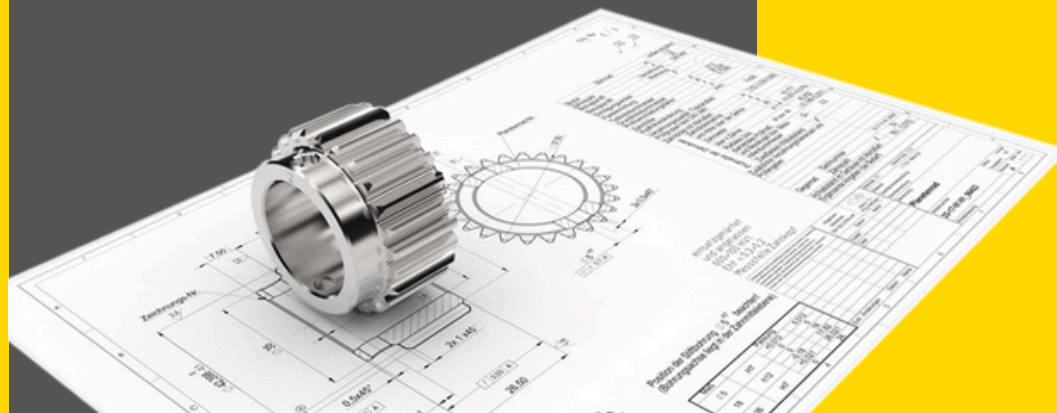

Our Manufacturing Capabilities

MACHINERY

CNC TURNING CENTERS
CNC VERTICLE MILLING CENTERS (VMC)
POLYGONE TURNING

Machining Capability

- Turning Dia.- 8mm to 250 mm
- Milling Size - 500mmx800mm
- Drilling
- Boring
- Threading
- Tolerance Upto 25µm

Surface Treatment

- Nickel Plating
- Chrome Plating
- Brass Plating
- Tin Plating
- Grinding
- Annealing



3-AXIS VMC MILLING

CNC-TURNED PARTS

POLYGON MACHINED PARTS

Parts & Components For All Industries



CLIENTELE



CURRENT PROJECT

Suspension Nut- 40000 Pcs./ Month



Work With Us

204 Pushpam Ind Est, Neeka tube compound,
Vatva GIDC Phase 1, Ahmedabad- 382445,
Gujarat, India

info@framech.com

www.framech.com

Contact: +91 94288 90684

Connect with US

